

WaterReel

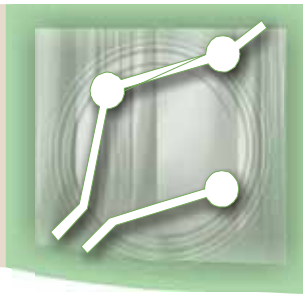

Water in Oil Level Detector



The WaterReel water in oil level detector is a compact, portable self-contained device which detects the presence and level of water contamination accumulated in the bottom of fuel oil storage tanks. It provides an early warning, alerting the

operator of the need to perform tank maintenance.

The sensor is lowered into the tank and presence of water immediately initiates a visible and audible alarm. A test button confirms correct function of the entire assembly—including cable and probe.

An approximation of the depth of water contamination can be determined by positioning the sensor on the tank base and then withdrawing it, noting the amount of cable exposed when the alarm ceases.

Operation is simple, a single press of the power button energises the unit for 5 minutes at a time. A low level "chirp" and flashing LED confirms operation, both of which increase in intensity on detecting water. A low battery LED illuminates in the event that battery replacement is required.

The unit uses 4 x AA batteries which are easily changed by the operator.



benefits

Completely Portable

Rugged Construction

Guards against potentially expensive engine / pump failures due to water ingress

Folding handle and sensor holster for easy storage

Uses standard Format AA Batteries (Eveready Energiser Lithium L91 for I.S. applications)

Military approved option available

specification

Cable: 4 core insulated 4.7mm dia grey modified polyurethane. Low smoke, Halogen free, suitable for oil immersion.

Probe current: <2mA ac, No dc current

Conductance threshold 10ms/cm @25°C

Materials: Probe 316 St Stl.

Reel assembly St Stl

Power source: 6V battery pack (4 x AA)

Operating &

Storage Temperature: -40 to +50°C

Intrinsic Safety: Eex ia IIB T4



PSM

WaterReel



Model coding

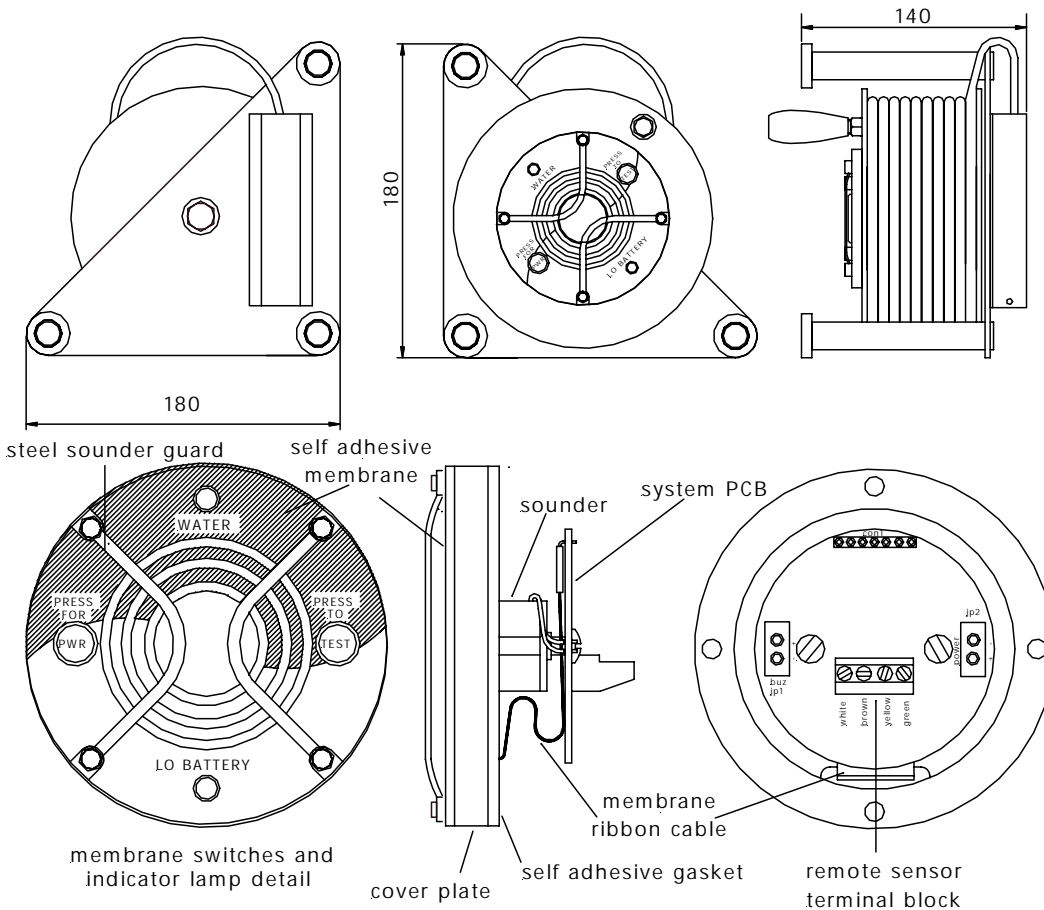
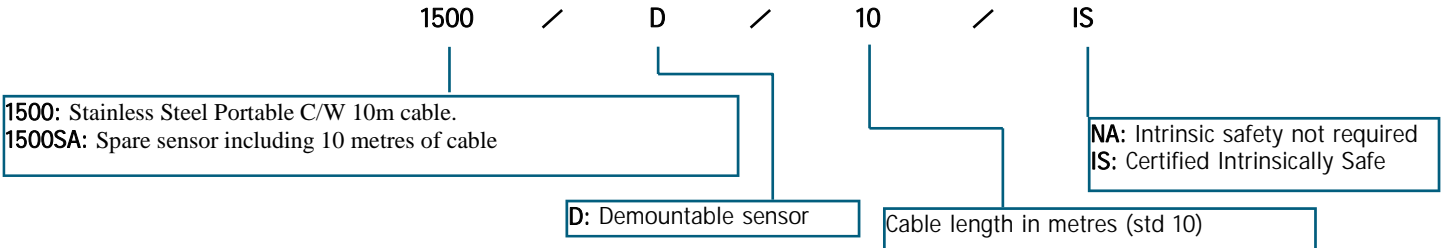

all welded submersible
st/stl sensor
25mm dia x 90
long [typ]

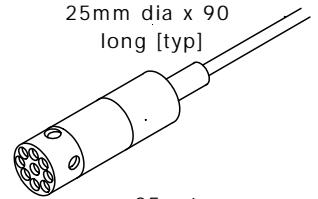

max 25 mtrs
high performance
flexible cable. HF-120.
4x0.14mm SQ, O/D5mm
Polyolefin insulation,
Polyurethane outer sheath

PSM

advice & enquiries

Telephone: +44 (0) 1444 410040

Fax: +44 (0) 1444 410121

Email: sales@psm-sensors.co.uk

Web: <http://www.psm-sensors.co.uk>

The WaterReel is a registered design. All rights reserved 2006

PSM Instrumentation Limited

Burrell Road Haywards Heath W Sussex RH16 1TW UK

T +44 (0) 1444 410040 F +44 (0) 1444 410121 W www.psm-sensors.co.uk E sales@psm-sensors.co.uk